

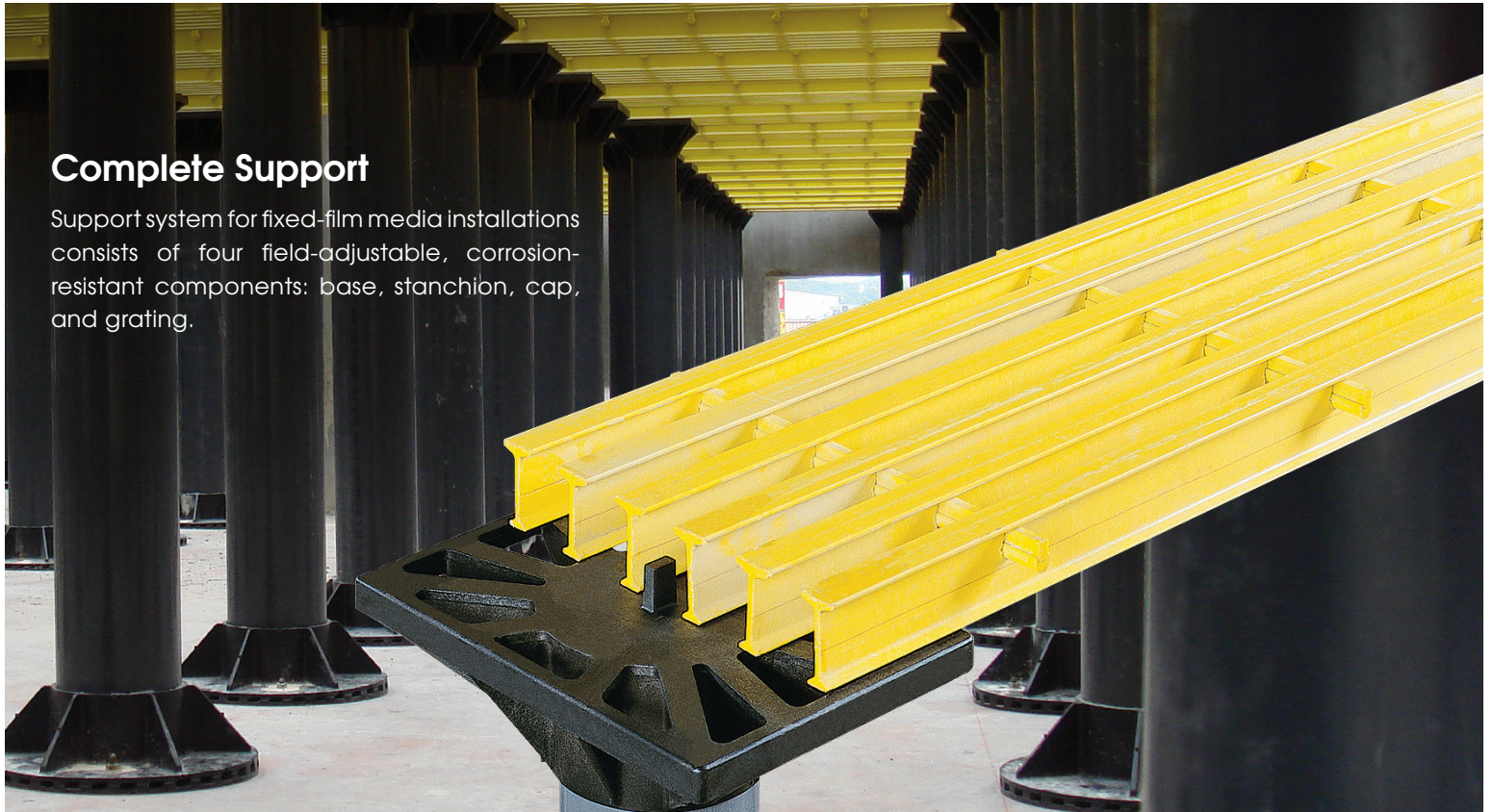

# ACCUPIER<sup>®</sup> SUPPORT SYSTEM

## Complete Support

Support system for fixed-film media installations consists of four field-adjustable, corrosion-resistant components: base, stanchion, cap, and grating.



## Features

- Less expensive than conventional poured concrete supports and pre-cast beams.
- Allows maximum airflow and wastewater flow below media.
- Practical solution for rock filter retrofits, tall biotowers, and submerged media systems.
- Quick and easy installation.



## AccuPier® Support System

AccuPier is a pre-engineered support system for structured-sheet media designed to replace formed-in-place concrete supports and heavy concrete crossbeams. A field-adjustable base and cut-to-length stanchions allow for installation in a variety of tank configurations. All components are engineered plastics for corrosion resistance and ease of installation. A complete system consists of an adjustable base, stanchion, cap, and grating.

### Engineered Components

- Adjustable base accommodates any floor slope up to 4%.
- Pier heights vary from 9" (23 cm) to 42" (107cm).
- Rated to hold 7,000 lbs (3176 kg) per pier.
- Pier caps and grating are designed with openings to maximize airflow and facilitate wastewater flow.

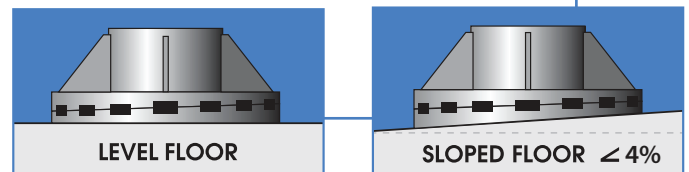
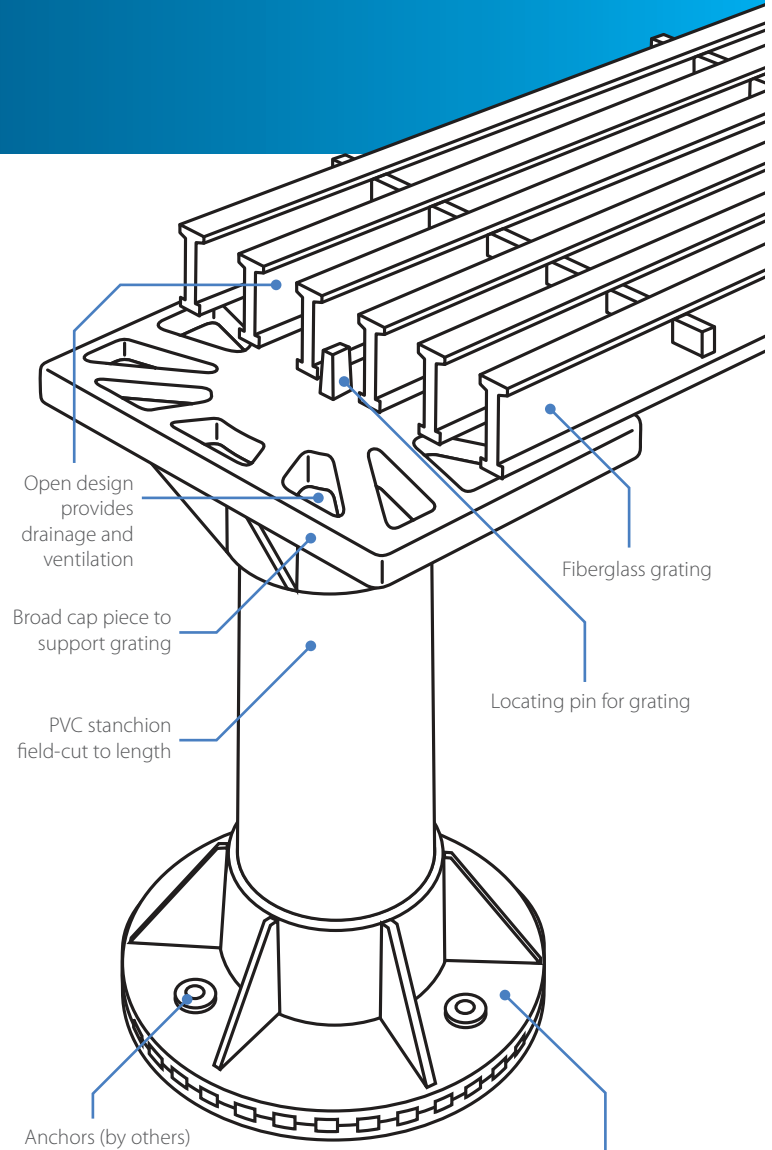

Wedge-shaped base discs rotate to accommodate floor slope.

## Why Brentwood?

Brentwood has the ability to provide you with products and solutions that offer safe and effective biological treatment, while also addressing your most complex environmental, cost, and treatment concerns. Brentwood's innovative design, manufacturing standards, and product testing yield field-proven systems of the highest quality, recognized worldwide for superior performance and long-lasting service.



### BRENTWOOD INDUSTRIES, INC.

brentwoodindustries.com  
tricklingfilter@brentw.com  
+1.610.374.5109

